

Analog Input Module (RTD, TC)

GT-3xxx User Manual



Version 1.0

2018 CREVIS Co.,Ltd

DOCUMENT CHANGE SUMMARY				
REV	PAGE	REMARKS	DATE	EDITOR
1.00	New Document		18/07/30	Jy Hyun

Table of Contents

1. Important Notes	5
1.1. Safety Instruction	6
1.1.1. Symbols	6
1.1.2. Safety Notes	6
1.1.3. Certification	6
2. Analog Input Module List	7
3. Specification	8
3.1. GT-3704	8
3.1.1. Wiring Diagram	8
3.1.2. LED Indicator	9
3.1.3. Channel Status LED	9
3.1.4. Environment Specification	10
3.1.5. Specification	11
3.1.6. Mapping Data into the Image Table	12
3.1.7. Configuration Parameter – 10 Bytes	13
3.1.8. Data Value	14
3.2. GT-3708	15
3.2.1. Wiring Diagram	15
3.2.2. LED Indicator	16
3.2.3. Channel Status LED	16
3.2.4. Environment Specification	17
3.2.5. Specification	18
3.2.6. Mapping Data into the Image Table	19
3.2.7. Configuration Parameter – 18 Bytes	20
3.2.8. Data Value	21
3.3. GT-3804	22
3.3.1. Wiring Diagram	22
3.3.2. LED Indicator	23
3.3.3. Channel Status LED	23
3.3.4. Environment Specification	24

3.3.5. Specification.....	25
3.3.6. Mapping Data into the Image Table.....	27
3.3.7. Configuration Parameter – 8 Bytes.....	28
3.3.8. Data Value.....	29
3.4. GT-3808.....	30
3.4.1. Wiring Diagram.....	30
3.4.2. LED Indicator.....	31
3.4.3. Channel Status LED.....	31
3.4.4. Environment Specification.....	32
3.4.5. Specification.....	33
3.4.6. Mapping Data into the Image Table.....	36
3.4.7. Configuration Parameter – 8 Bytes.....	37
3.4.8. Data Value.....	38
4. Dimension.....	39
4.1. GT-3xx4(RTB), GT-3xx8(RTB).....	39
4.2. GT-3xxF(Connector).....	40
5. Mounting.....	41
5.1. I/O Inserting and Removing Devices.....	41
5.2. RTB (Removable Terminal Block).....	42
6. G-Bus Pin Description.....	43

1. Important Notes

Solid state equipment has operational characteristics differing from those of electromechanical equipment.

Safety Guidelines for the Application, Installation and Maintenance of Solid State Controls describes some important differences between solid state equipment and hard-wired electromechanical devices.

Because of this difference, and also because of the wide variety of uses for solid state equipment, all persons responsible for applying this equipment must satisfy themselves that each intended application of this equipment is acceptable.

In no event will CREVIS be responsible or liable for indirect or consequential damages resulting from the use or application of this equipment.

The examples and diagrams in this manual are included solely for illustrative purposes. Because of the many variables and requirements associated with any particular installation, CREVIS cannot assume responsibility or liability for actual use based on the examples and diagrams.

Warning!



- ✓ **If you don't follow the directions, it could cause a personal injury, damage to the equipment or explosion**
- Do not assemble the products and wire with power applied to the system. Else it may cause an electric arc, which can result into unexpected and potentially dangerous action by field devices. Arching is explosion risk in hazardous locations. Be sure that the area is non-hazardous or remove system power appropriately before assembling or wiring the modules.
- Do not touch any terminal blocks or IO modules when system is running. Else it may cause the unit to an electric shock or malfunction.
- Keep away from the strange metallic materials not related to the unit and wiring works should be controlled by the electric expert engineer. Else it may cause the unit to a fire, electric shock or malfunction

Caution!

- ✓ **If you disobey the instructions, there may be possibility of personal injury, damage to equipment or explosion. Please follow below Instructions.**
- Check the rated voltage and terminal array before wiring. Avoid the circumstances over 50°C of temperature. Avoid placing it directly in the sunlight.
- Avoid the place under circumstances over 85% of humidity.
- Do not place Modules near by the inflammable material. Else it may cause a fire.
- Do not permit any vibration approaching it directly.
- Go through module specification carefully, ensure inputs, output connections are made with the specifications. Use standard cables for wiring.
- Use Product under pollution degree 2 environment.

1.1. Safety Instruction

1.1.1. Symbols

<p>DANGER</p> 	<p>Identifies information about practices or circumstances that can cause an explosion in a hazardous environment, which may lead to personal injury or death property damage, or economic loss</p>
<p>IMPORTANT</p>	<p>Identifies information that is critical for successful application and understanding of the product</p>
<p>ATTENTION</p> 	<p>Identifies information about practices or circumstances that can lead to personal injury, property damage, or economic loss. Attentions help you to identify a hazard, avoid a hazard, and recognize the consequences</p>

1.1.2. Safety Notes

<p>DANGER</p> 	<p>The modules are equipped with electronic components that may be destroyed by electrostatic discharge. When handling the modules, ensure that the environment (persons, workplace and packing) is well grounded. Avoid touching conductive components, G-BUS Pin.</p>
--	---

1.1.3. Certification

c-UL-us UL Listed Industrial Control Equipment, certified for U.S. and Canada

See UL File E235505

CE Certificate

EN 61000-6-2; Industrial Immunity

EN 61000-6-4; Industrial Emissions

Reach, RoHS (EU, CHINA)

2. Analog Input Module List

GT-Number	Description	ID	Production Status
GT-3704	Analog Input 4 Channels, RTD / Resistance Input, 10RTB	3704	Active
GT-3708	Analog Input 8 Channels, RTD / Resistance Input, 20P Connector	3708	Active
GT-3804	Analog Input 4 Channels, Thermocouple / mV Input, 10RTB	3804	Active
GT-3808	Analog Input 8 Channels, Thermocouple / mV Input, 20P Connector	3808	Active

3. Specification

3.1. GT-3704

3.1.1. Wiring Diagram

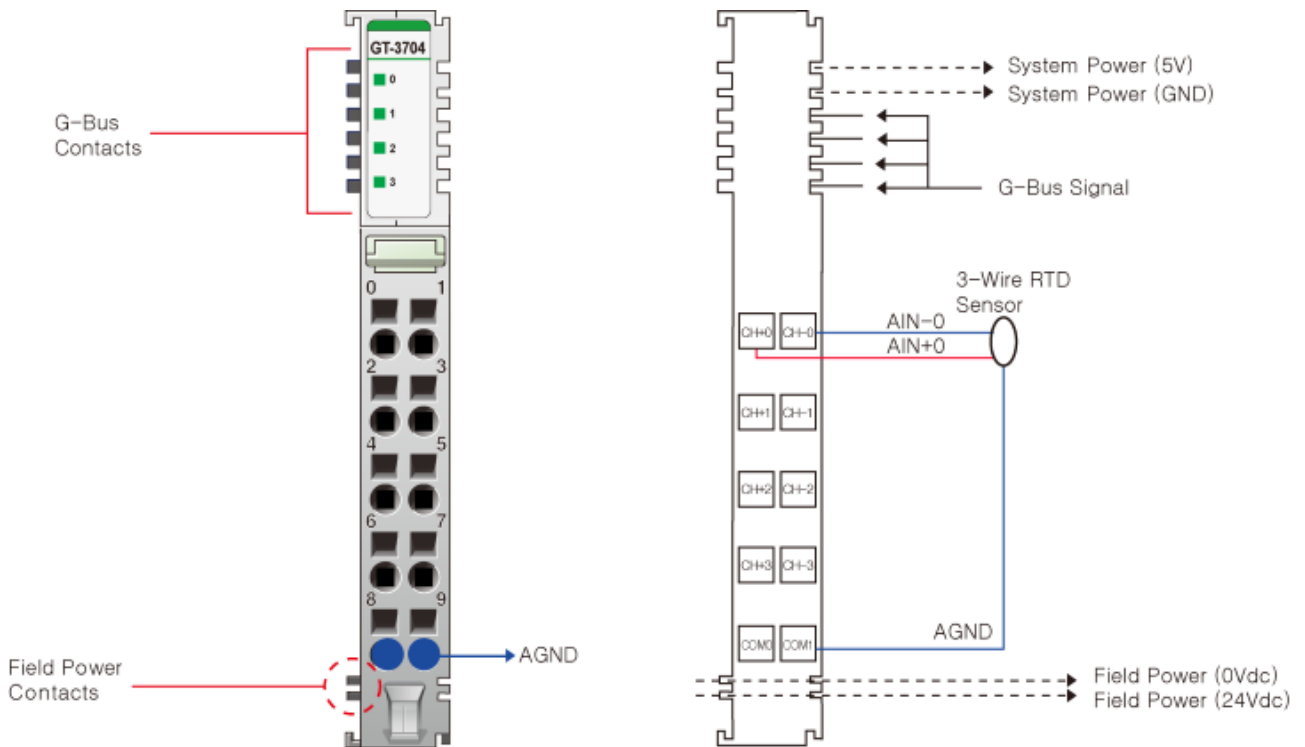

Pin No.	Signal Description	Signal Description	Pin No.
0	RTD Channel 0+	RTD Channel 0-	1
2	RTD Channel 1+	RTD Channel 1-	3
4	RTD Channel 2+	RTD Channel 2-	5
6	RTD Channel 3+	RTD Channel 3-	7
8	AGND	AGND	9

3.1.2. LED Indicator



LED No.	LED Function / Description	LED Color
0	Input Channel 0	Green
1	Input Channel 1	Green
2	Input Channel 2	Green
3	Input Channel 3	Green

3.1.3. Channel Status LED

Status	LED	To indicate
No Signal	Off	Input Sensor Open or Input Range Over
Normal Operation		Normal Operation
On Signal	Green	Sensor Connected and Input Range Valid
Normal Operation		Normal Operation

3.1.4. Environment Specification

Environmental Specification	
Operation Temperature	-40°C ~ 70°C
UL Temperature	-20°C ~ 60°C
Storage Temperature	-40°C ~ 85°C
Relative Humidity	5% ~ 90% Non-condensing
Mounting	DIN Rail
General Specification	
Shock Operating	IEC 60068-2-27
Vibration Resistance	Based on IEC 60068-2-6 Sine Vibration - 5 ~ 25Hz : ±1.6mm - 25 ~ 300Hz : 4g - Sweep Rate : 1 Oct/min, 20 Sweeps Random Vibration - 10 ~ 40 Hz : 0.0125 g ² /Hz - 40 ~ 100 Hz : 0.0125 → 0.002 g ² /Hz - 100 ~ 500 Hz : 0.002 g ² /Hz - 500 ~ 2000 Hz : 0.002 → 1.3 x 10 ⁻⁴ g ² /Hz - Test time : 1hrs for each test
EMC Resistance Burst/ESD	EN 61000-6-2 : 2005 EN61000-6-4/All : 2011
Protection Class	Variable/IP20
Installation Position	Vertical and horizontal installation is available
Product Certifications	CE, UL

3.1.5. Specification

Items																													
Input Specification																													
Inputs Per Module	4 Channels																												
Indicators	4 Green Input Status LEDs																												
Sensor Types	RTD Input Range																												
	<table border="1"> <thead> <tr> <th>RTD Input</th> <th>Input Range</th> </tr> </thead> <tbody> <tr> <td>PT100, PT200, PT500, PT50</td> <td>-200~850°C</td> </tr> <tr> <td>PT1000</td> <td>-200~350°C</td> </tr> <tr> <td>JPT100, JPT200, JPT500, JPT50</td> <td>-200~640°C</td> </tr> <tr> <td>JPT1000</td> <td>-200~350°C</td> </tr> <tr> <td>NI 100, NI 200, NI 500</td> <td>-60~250°C</td> </tr> <tr> <td>NI 1000</td> <td>-60~180°C</td> </tr> <tr> <td>NI 120</td> <td>-80~260°C</td> </tr> <tr> <td>NI 1000LG</td> <td>-50~120°C</td> </tr> <tr> <th>Resistance Input</th> <th>Input Range</th> </tr> <tr> <td>100mΩ/Bit</td> <td>0~2000Ω</td> </tr> <tr> <td>10mΩ/Bit</td> <td>0~327Ω</td> </tr> <tr> <td>20mΩ/Bit</td> <td>0~620Ω</td> </tr> <tr> <td>50mΩ/Bit</td> <td>0~1200Ω</td> </tr> </tbody> </table>	RTD Input	Input Range	PT100, PT200, PT500, PT50	-200~850°C	PT1000	-200~350°C	JPT100, JPT200, JPT500, JPT50	-200~640°C	JPT1000	-200~350°C	NI 100, NI 200, NI 500	-60~250°C	NI 1000	-60~180°C	NI 120	-80~260°C	NI 1000LG	-50~120°C	Resistance Input	Input Range	100mΩ/Bit	0~2000Ω	10mΩ/Bit	0~327Ω	20mΩ/Bit	0~620Ω	50mΩ/Bit	0~1200Ω
	RTD Input	Input Range																											
	PT100, PT200, PT500, PT50	-200~850°C																											
	PT1000	-200~350°C																											
	JPT100, JPT200, JPT500, JPT50	-200~640°C																											
	JPT1000	-200~350°C																											
	NI 100, NI 200, NI 500	-60~250°C																											
	NI 1000	-60~180°C																											
	NI 120	-80~260°C																											
	NI 1000LG	-50~120°C																											
	Resistance Input	Input Range																											
	100mΩ/Bit	0~2000Ω																											
	10mΩ/Bit	0~327Ω																											
	20mΩ/Bit	0~620Ω																											
50mΩ/Bit	0~1200Ω																												
Excitation Current	About 1mA																												
Connection Method	3-Wire																												
Conversion Time	< 150ms, All Channel																												
Data Format	16 Bits signed Integer (2' complement)																												
Module Accuracy	PT100, PT1000 Type Input Range - 0.5°C Full Scale @ 25°C ambient All Type Input Range - ±0.1% Full Scale @ 25°C ambient - ±0.3% Full Scale @ -40, 70°C ambient																												
Resolution of Data	RTD Type : ±0.1°C / F, Resistance Type : 100mΩ, 10mΩ, 20mΩ, 50mΩ																												
Calibration	Not Required																												
Diagnostic	Sensor open or range over, then conversion data = 0x8000(-32768)																												
General Specification																													
Power Dissipation	Max. 130mA @ 5Vdc																												
Isolation	I/O to Logic : Photocoupler Isolation Field power : Not Connected																												
Field Power	Not used, Field Power passes through to the next module																												
Wiring	I/O Cable Max. 2.0mm ² (AWG 14)																												
Weight	60g																												
Module Size	12mm x 99mm x 70mm																												
Environment Condition	Refer to 'Environment Specification'																												

3.1.6. Mapping Data into the Image Table

- **Input Module Data**

	Analog Input Ch0
	Analog Input Ch1
	Analog Input Ch2
	Analog Input Ch3

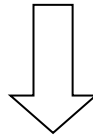

- **Input Image Value**

Bit No	Bit7	Bit6	Bit5	Bit4	Bit3	Bit2	Bit1	Bit0
Byte 0					Analog Input Ch0 Low byte			
Byte 1					Analog Input Ch0 High byte			
Byte 2					Analog Input Ch1 Low byte			
Byte 3					Analog Input Ch1 High byte			
Byte 4					Analog Input Ch2 Low byte			
Byte 5					Analog Input Ch2 High byte			
Byte 6					Analog Input Ch3 Low byte			
Byte 7					Analog Input Ch3 High byte			

- If the input of channel is open or over-ranged, its conversion data will be 0x8000(-32678)

3.1.7. Configuration Parameter – 10 Bytes

Byte	Decimal Bit	Description	Default Value
0	00-07	The selection Sensor Type =00h:PT100, 0.00385, -200~850°C, 0.1°C/count =01h:PT200, 0.00385, -200~850°C, 0.1°C/count =02h:PT500, 0.00385, -200~850°C, 0.1°C/count =03h:PT1000, 0.00385, -200~350°C, 0.1°C/count =04h:PT50, 0.00385, -200~850°C, 0.1°C/count =10h:JPT100, 0.003916, -200~640°C, 0.1°C/count =11h:JPT200, 0.003916, -200~640°C, 0.1°C/count =12h:JPT500, 0.003916, -200~640°C, 0.1°C/count =13h:JPT1000, 0.003916, -200~350°C, 0.1°C/count =14h:JPT50, 0.003916, -200~640°C, 0.1°C/count =20h:NI100, 0.00618, -60~250°C, 0.1°C/count =21h:NI200, 0.00618, -60~250°C, 0.1°C/count =22h:NI500, 0.00618, -60~250°C, 0.1°C/count =23h:NI1000, 0.00618, -60~180°C, 0.1°C/count =30h:NI120, 0.00672, -80~250°C, 0.1°C/count =53h:NI1000LG, 0.00500, -50~120°C, 0.1°C/count =80h:Resistance Input, 1~2000Ω, 100mΩ /1count =81h:Resistance Input, 1~327Ω, 10mΩ /1count =82h:Resistance Input, 1~620Ω, 20mΩ /1count =83h: Resistance Input, 1~1200Ω, 50mΩ/1count =Others: Reserved	0: PT100
1	00	Temperature Type 0: Celsius(°C), 1: Fahrenheit(°F)	0: Celsius(°C)
	01	Reserved	0
	02	Data Resolution 0: 0.1°C, °F/Bit, 1: 1°C, °F/Bit	0
	03	Reserved	0
	04	Filter Type 0: Normal Filter, 1: Enhanced Filter	0: Normal Filter
	05-07	Reserved	0
2~3	-	CH0 Offset Value	0
4~5	-	CH1 Offset Value	0
6~7	-	CH2 Offset Value	0
8~9	-	CH3 Offset Value	0

3.1.8. Data Value

Resistance Temperature Detector Input Range	
Type	Input Range
PT100	-200 ~ 850 °C
PT200	-200 ~ 850 °C
PT500	-200 ~ 850 °C
PT1000	-200 ~ 350 °C
PT50	-200 ~ 850 °C
JPT100	-200 ~ 640 °C
JPT200	-200 ~ 640 °C
JPT500	-200 ~ 640 °C
JPT1000	-200 ~ 350 °C
JPT50	-200 ~ 640 °C
NI100	-60 ~ 250 °C
NI200	-60 ~ 250 °C
NI500	-60 ~ 250 °C
NI1000	-60 ~ 180 °C
NI120	-80 ~ 260 °C
NI1000LG	-50 ~ 120 °C
Resistance Input Range	
Type	Input Range
100mΩ/Bit	0~2000Ω
10mΩ/Bit	0~327Ω
20mΩ/Bit	0~620Ω
50mΩ/Bit	0~1200Ω

3.2. GT-3708

3.2.1. Wiring Diagram

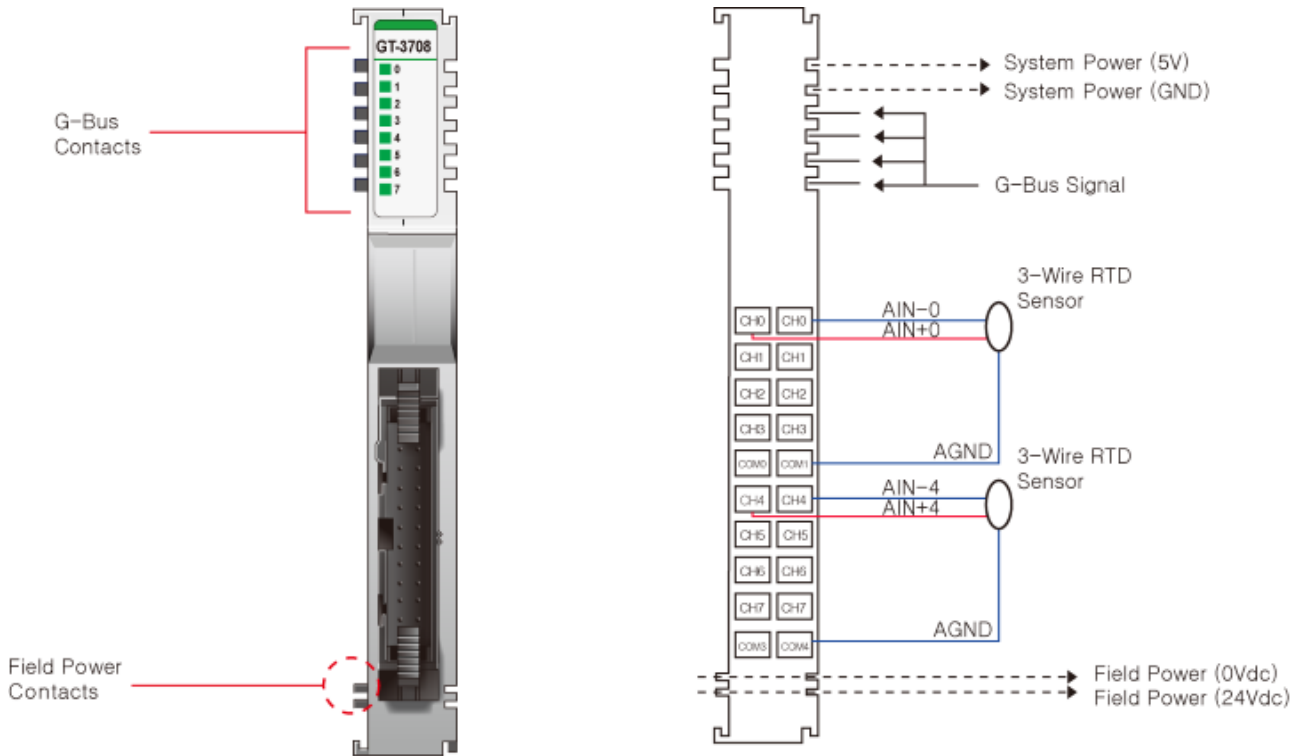

Pin No.	Signal Description	Signal Description	Pin No.
0	RTD Channel 0+	RTD Channel 0-	1
2	RTD Channel 1+	RTD Channel 1-	3
4	RTD Channel 2+	RTD Channel 2-	5
6	RTD Channel 3+	RTD Channel 3-	7
8	AGND	AGND	9
10	RTD Channel 4+	RTD Channel 4-	11
12	RTD Channel 5+	RTD Channel 5-	13
14	RTD Channel 6+	RTD Channel 6-	15
16	RTD Channel 7+	RTD Channel 7-	17
18	AGND	AGND	19

3.2.2. LED Indicator

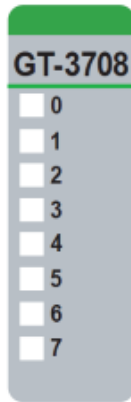

LED No.	LED Function / Description	LED Color
0	Input Channel 0	Green
1	Input Channel 1	Green
2	Input Channel 2	Green
3	Input Channel 3	Green
4	Input Channel 4	Green
5	Input Channel 5	Green
6	Input Channel 6	Green
7	Input Channel 7	Green

3.2.3. Channel Status LED

Status	LED	To indicate
No Signal	Off	Input Sensor Open or Input Range Over
Normal Operation		Normal Operation
On Signal	Green	Sensor Connected and Input Range Valid
Normal Operation		Normal Operation

3.2.4. Environment Specification

Environmental Specification	
Operation Temperature	-40°C ~ 70°C
UL Temperature	-20°C ~ 60°C
Storage Temperature	-40°C ~ 85°C
Relative Humidity	5% ~ 90% Non-condensing
Mounting	DIN Rail
General Specification	
Shock Operating	IEC 60068-2-27
Vibration Resistance	Based on IEC 60068-2-6 Sine Vibration - 5 ~ 25Hz : ±1.6mm - 25 ~ 300Hz : 4g - Sweep Rate : 1 Oct/min, 20 Sweeps Random Vibration - 10 ~ 40 Hz : 0.0125 g ² /Hz - 40 ~ 100 Hz : 0.0125 → 0.002 g ² /Hz - 100 ~ 500 Hz : 0.002 g ² /Hz - 500 ~ 2000 Hz : 0.002 → 1.3 x 10 ⁻⁴ g ² /Hz - Test time : 1hrs for each test
EMC Resistance Burst/ESD	EN 61000-6-2 : 2005 EN61000-6-4/All : 2011
Protection Class	Variable/IP20
Installation Position	Vertical and horizontal installation is available
Product Certifications	CE, UL

3.2.5. Specification

Items																													
Input Specification																													
Inputs Per Module	8 Channels																												
Indicators	8 Green Input Status LEDs																												
Sensor Types	RTD Input Range																												
	<table border="1"> <thead> <tr> <th>RTD Input</th> <th>Input Range</th> </tr> </thead> <tbody> <tr> <td>PT100, PT200, PT500, PT50</td> <td>-200~850°C</td> </tr> <tr> <td>PT1000</td> <td>-200~350°C</td> </tr> <tr> <td>JPT100, JPT200, JPT500, JPT50</td> <td>-200~640°C</td> </tr> <tr> <td>JPT1000</td> <td>-200~350°C</td> </tr> <tr> <td>NI 100, NI 200, NI 500</td> <td>-60~250°C</td> </tr> <tr> <td>NI 1000</td> <td>-60~180°C</td> </tr> <tr> <td>NI 120</td> <td>-80~260°C</td> </tr> <tr> <td>NI 1000LG</td> <td>-50~120°C</td> </tr> <tr> <th>Resistance Input</th> <th>Input Range</th> </tr> <tr> <td>100mΩ/Bit</td> <td>0~2000Ω</td> </tr> <tr> <td>10mΩ/Bit</td> <td>0~327Ω</td> </tr> <tr> <td>20mΩ/Bit</td> <td>0~620Ω</td> </tr> <tr> <td>50mΩ/Bit</td> <td>0~1200Ω</td> </tr> </tbody> </table>	RTD Input	Input Range	PT100, PT200, PT500, PT50	-200~850°C	PT1000	-200~350°C	JPT100, JPT200, JPT500, JPT50	-200~640°C	JPT1000	-200~350°C	NI 100, NI 200, NI 500	-60~250°C	NI 1000	-60~180°C	NI 120	-80~260°C	NI 1000LG	-50~120°C	Resistance Input	Input Range	100mΩ/Bit	0~2000Ω	10mΩ/Bit	0~327Ω	20mΩ/Bit	0~620Ω	50mΩ/Bit	0~1200Ω
	RTD Input	Input Range																											
	PT100, PT200, PT500, PT50	-200~850°C																											
	PT1000	-200~350°C																											
	JPT100, JPT200, JPT500, JPT50	-200~640°C																											
	JPT1000	-200~350°C																											
	NI 100, NI 200, NI 500	-60~250°C																											
	NI 1000	-60~180°C																											
	NI 120	-80~260°C																											
	NI 1000LG	-50~120°C																											
	Resistance Input	Input Range																											
	100mΩ/Bit	0~2000Ω																											
	10mΩ/Bit	0~327Ω																											
	20mΩ/Bit	0~620Ω																											
50mΩ/Bit	0~1200Ω																												
Excitation Current	About 1mA																												
Connection Method	3-Wire																												
Conversion Time	< 280ms, All Channel																												
Data Format	16 Bits signed Integer (2' complement)																												
Module Accuracy	PT100, PT1000 Type Input Range - 0.5°C Full Scale @ 25°C ambient All Type Input Range - ±0.1% Full Scale @ 25°C ambient - ±0.3% Full Scale @ -40, 70°C ambient																												
Resolution of Data	RTD Type : ±0.1°C / F, Resistance Type : 100mΩ, 10mΩ, 20mΩ, 50mΩ																												
Calibration	Not Required																												
Diagnostic	Sensor open or range over, then conversion data = 0x8000(-32768)																												
General Specification																													
Power Dissipation	Max. 120mA @ 5Vdc																												
Isolation	I/O to Logic : Photocoupler Isolation Field power : Not Connected																												
Field Power	Not used, Field Power passes through to the next module																												
Wiring	I/O Cable Max. 2.0mm ² (AWG 14)																												
Weight	60g																												
Module Size	12mm x 99mm x 70mm																												
Environment Condition	Refer to 'Environment Specification'																												

3.2.6. Mapping Data into the Image Table

- **Input Module Data**

	Analog Input Ch0
	Analog Input Ch1
	Analog Input Ch2
	Analog Input Ch3
	Analog Input Ch4
	Analog Input Ch5
	Analog Input Ch6
	Analog Input Ch7

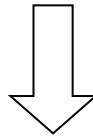

- **Input Image Value**

Bit No	Bit7	Bit6	Bit5	Bit4	Bit3	Bit2	Bit1	Bit0
Byte 0	Analog Input Ch0 Low byte							
Byte 1	Analog Input Ch0 High byte							
Byte 2	Analog Input Ch1 Low byte							
Byte 3	Analog Input Ch1 High byte							
Byte 4	Analog Input Ch2 Low byte							
Byte 5	Analog Input Ch2 High byte							
Byte 6	Analog Input Ch3 Low byte							
Byte 7	Analog Input Ch3 High byte							
Byte 8	Analog Input Ch4 Low byte							
Byte 9	Analog Input Ch4 High byte							
Byte 10	Analog Input Ch5 Low byte							
Byte 11	Analog Input Ch5 High byte							
Byte 12	Analog Input Ch6 Low byte							
Byte 13	Analog Input Ch6 High byte							
Byte 14	Analog Input Ch7 Low byte							
Byte 15	Analog Input Ch7 High byte							

- If the input of channel is open or over-ranged, its conversion data will be 0x8000(-32678)

3.2.7. Configuration Parameter – 18 Bytes

Byte	Decimal Bit	Description	Default Value
0	00-07	The selection Sensor Type =00h:PT100, 0.00385, -200~850°C, 0.1°C/count =01h:PT200, 0.00385, -200~850°C, 0.1°C/count =02h:PT500, 0.00385, -200~850°C, 0.1°C/count =03h:PT1000, 0.00385, -200~350°C, 0.1°C/count =04h:PT50, 0.00385, -200~850°C, 0.1°C/count =10h:JPT100, 0.003916, -200~640°C, 0.1°C/count =11h:JPT200, 0.003916, -200~640°C, 0.1°C/count =12h:JPT500, 0.003916, -200~640°C, 0.1°C/count =13h:JPT1000, 0.003916, -200~350°C, 0.1°C/count =14h:JPT50, 0.003916, -200~640°C, 0.1°C/count =20h:NI100, 0.00618, -60~250°C, 0.1°C/count =21h:NI200, 0.00618, -60~250°C, 0.1°C/count =22h:NI500, 0.00618, -60~250°C, 0.1°C/count =23h:NI1000, 0.00618, -60~180°C, 0.1°C/count =30h:NI120, 0.00672, -80~250°C, 0.1°C/count =53h:NI1000LG, 0.00500, -50~120°C, 0.1°C/count =80h:Resistance Input, 1~2000Ω, 100mΩ /1count =81h:Resistance Input, 1~327Ω, 10mΩ /1count =82h:Resistance Input, 1~620Ω, 20mΩ /1count =83h: Resistance Input, 1~1200Ω, 50mΩ/1count =Others: Reserved	0: PT100
1	00	Temperature Type 0: Celsius(°C), 1: Fahrenheit(°F)	0: Celsius(°C)
	01	Reserved	0
	02	Data Resolution 0: 0.1°C, °F/Bit, 1: 1°C, °F/Bit	0
	03	Reserved	0
	04	Filter Type 0: Normal Filter, 1: Enhanced Filter	0: Normal Filter
	05-07	Reserved	0
2~3	-	CH0 Offset Value	0
4~5	-	CH1 Offset Value	0
6~7	-	CH2 Offset Value	0
8~9	-	CH3 Offset Value	0
10~11	-	CH4 Offset Value	0
12~13	-	CH5 Offset Value	0
14~15	-	CH6 Offset Value	0
16~17	-	CH7 Offset Value	0

3.2.8. Data Value

Resistance Temperature Detector Input Range	
Type	Input Range
PT100	-200 ~ 850 °C
PT200	-200 ~ 850 °C
PT500	-200 ~ 850 °C
PT1000	-200 ~ 350 °C
PT50	-200 ~ 850 °C
JPT100	-200 ~ 640 °C
JPT200	-200 ~ 640 °C
JPT500	-200 ~ 640 °C
JPT1000	-200 ~ 350 °C
JPT50	-200 ~ 640 °C
NI100	-60 ~ 250 °C
NI200	-60 ~ 250 °C
NI500	-60 ~ 250 °C
NI1000	-60 ~ 180 °C
NI120	-80 ~ 260 °C
NI1000LG	-50 ~ 120 °C
Resistance Input Range	
Type	Input Range
100mΩ/Bit	0~2000Ω
10mΩ/Bit	0~327Ω
20mΩ/Bit	0~620Ω
50mΩ/Bit	0~1200Ω

3.3. GT-3804

3.3.1. Wiring Diagram

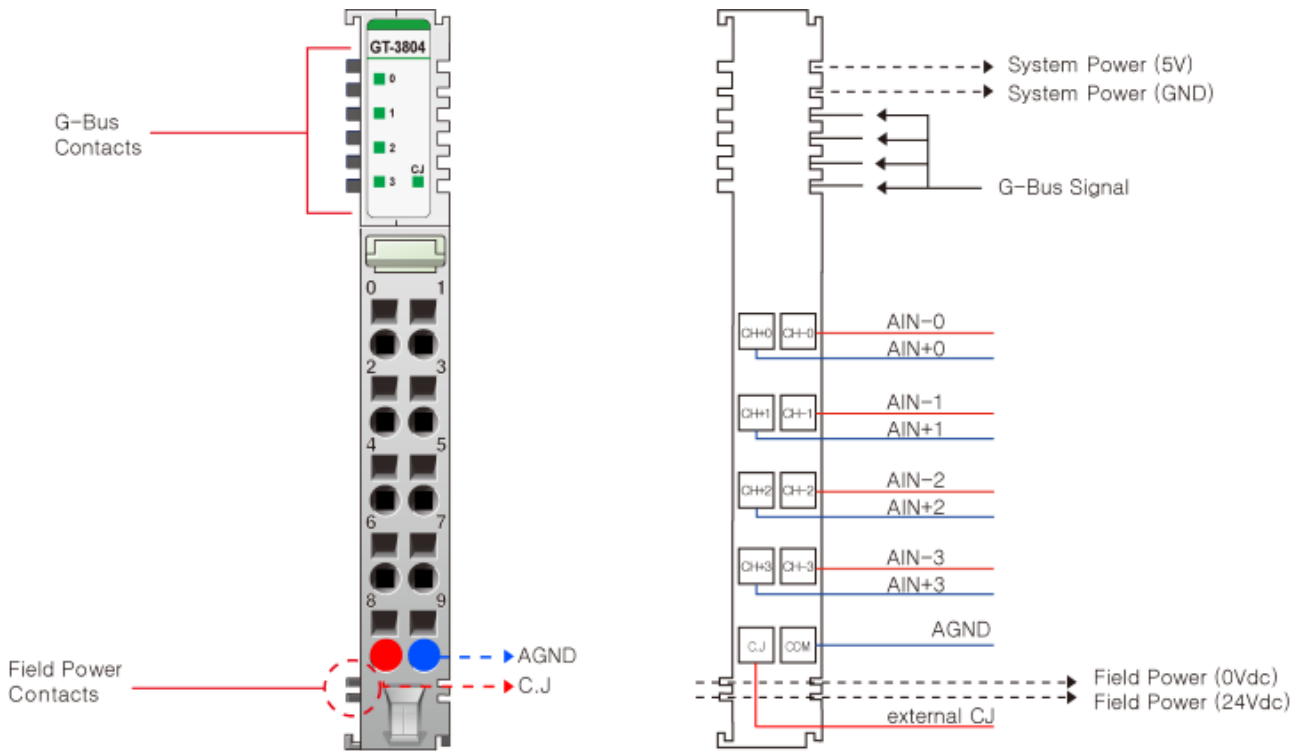

Figure 1. Customer Wiring to Mounting Base

Pin No.	Signal Description	Signal Description	Pin No.
0	TC Channel 0+	TC Channel 0-	1
2	TC Channel 1+	TC Channel 1-	3
4	TC Channel 2+	TC Channel 2-	5
6	TC Channel 3+	TC Channel 3-	7
8	Cold Junction Sensor	AGND	9

3.3.2. LED Indicator



LED No.	LED Function / Description	LED Color
0	Input Channel 0	Green
1	Input Channel 1	Green
2	Input Channel 2	Green
3	Input Channel 3	Green
CJ	Input Channel CJ	Green

3.3.3. Channel Status LED

Status	LED	To indicate
No Signal	Channel Off, CJ Off	Input Sensor Open or Input Range Over
Normal Operation		Normal Operation
On Signal	Channel On, CJ Off	Sensor Connected and Input Range Valid
Normal Operation		Normal Operation
On Signal	Channel On, CJ On	Sensor Connected and Input Range Valid
Normal Operation		Normal Operation
Connected External CJC		External CJ Enable

3.3.4. Environment Specification

Environmental Specification	
Operation Temperature	-40°C ~ 70°C
UL Temperature	-20°C ~ 60°C
Storage Temperature	-40°C ~ 85°C
Relative Humidity	5% ~ 90% Non-condensing
Mounting	DIN Rail
General Specification	
Shock Operating	IEC 60068-2-27
Vibration Resistance	Based on IEC 60068-2-6 Sine Vibration - 5 ~ 25Hz : ±1.6mm - 25 ~ 300Hz : 4g - Sweep Rate : 1 Oct/min, 20 Sweeps Random Vibration - 10 ~ 40 Hz : 0.0125 g ² /Hz - 40 ~ 100 Hz : 0.0125 → 0.002 g ² /Hz - 100 ~ 500 Hz : 0.002 g ² /Hz - 500 ~ 2000 Hz : 0.002 → 1.3 x 10 ⁻⁴ g ² /Hz - Test time : 1hrs for each test
EMC Resistance Burst/ESD	EN 61000-6-2 : 2005 EN61000-6-4/All : 2011
Protection Class	Variable/IP20
Installation Position	Vertical and horizontal installation is available
Product Certifications	CE, UL

3.3.5. Specification

Items	Specification																																																
Input Specification																																																	
Inputs Per Module	4 Channels																																																
Indicators	4 Green Input Status LEDs , 1 Green Input CJ Status LED																																																
Sensor Types	Thermal Couple Input Range																																																
	<table border="1"> <thead> <tr> <th>Type</th> <th>Maximum Input Range</th> <th>Recommended Input Range</th> </tr> </thead> <tbody> <tr> <td>K</td> <td>-270 ~ 1372°C</td> <td>-200 ~ 1200°C</td> </tr> <tr> <td>J</td> <td>-210 ~ 1200°C</td> <td>-40 ~ 1100°C</td> </tr> <tr> <td>T</td> <td>-270 ~ 400°C</td> <td>-200 ~ 350°C</td> </tr> <tr> <td>B</td> <td>30 ~ 1820°C</td> <td>600 ~ 1700°C</td> </tr> <tr> <td>R</td> <td>-50~1768°C</td> <td>0 ~ 1600°C</td> </tr> <tr> <td>S</td> <td>-50 ~ 1768°C</td> <td>0 ~ 1600°C</td> </tr> <tr> <td>E</td> <td>-270 ~ 1000°C</td> <td>-200 ~ 800°C</td> </tr> <tr> <td>N</td> <td>-270 ~ 1300°C</td> <td>-200 ~ 1250°C</td> </tr> <tr> <td>L</td> <td>-200 ~ 900°C</td> <td>-100 ~ 850°C</td> </tr> <tr> <td>U</td> <td>-200 ~ 600°C</td> <td>-100 ~ 550°C</td> </tr> <tr> <td>C</td> <td>0 ~ 2310°C</td> <td>100 ~ 2100°C</td> </tr> <tr> <td>D</td> <td>0 ~ 2490°C</td> <td>100 ~ 2200°C</td> </tr> <tr> <td>10uV Input</td> <td colspan="2">-81.0 ~ 81.0mV, 10uV/1 Count</td> </tr> <tr> <td>1uV Input</td> <td colspan="2">-32.7 ~ 32.7mV, 1uV/1 Count</td> </tr> <tr> <td>2uV Input</td> <td colspan="2">-65.5 ~ 65.5mV, 2uV/1 Count</td> </tr> </tbody> </table>	Type	Maximum Input Range	Recommended Input Range	K	-270 ~ 1372°C	-200 ~ 1200°C	J	-210 ~ 1200°C	-40 ~ 1100°C	T	-270 ~ 400°C	-200 ~ 350°C	B	30 ~ 1820°C	600 ~ 1700°C	R	-50~1768°C	0 ~ 1600°C	S	-50 ~ 1768°C	0 ~ 1600°C	E	-270 ~ 1000°C	-200 ~ 800°C	N	-270 ~ 1300°C	-200 ~ 1250°C	L	-200 ~ 900°C	-100 ~ 850°C	U	-200 ~ 600°C	-100 ~ 550°C	C	0 ~ 2310°C	100 ~ 2100°C	D	0 ~ 2490°C	100 ~ 2200°C	10uV Input	-81.0 ~ 81.0mV, 10uV/1 Count		1uV Input	-32.7 ~ 32.7mV, 1uV/1 Count		2uV Input	-65.5 ~ 65.5mV, 2uV/1 Count	
	Type	Maximum Input Range	Recommended Input Range																																														
	K	-270 ~ 1372°C	-200 ~ 1200°C																																														
	J	-210 ~ 1200°C	-40 ~ 1100°C																																														
	T	-270 ~ 400°C	-200 ~ 350°C																																														
	B	30 ~ 1820°C	600 ~ 1700°C																																														
	R	-50~1768°C	0 ~ 1600°C																																														
	S	-50 ~ 1768°C	0 ~ 1600°C																																														
	E	-270 ~ 1000°C	-200 ~ 800°C																																														
	N	-270 ~ 1300°C	-200 ~ 1250°C																																														
	L	-200 ~ 900°C	-100 ~ 850°C																																														
	U	-200 ~ 600°C	-100 ~ 550°C																																														
	C	0 ~ 2310°C	100 ~ 2100°C																																														
	D	0 ~ 2490°C	100 ~ 2200°C																																														
10uV Input	-81.0 ~ 81.0mV, 10uV/1 Count																																																
1uV Input	-32.7 ~ 32.7mV, 1uV/1 Count																																																
2uV Input	-65.5 ~ 65.5mV, 2uV/1 Count																																																
Module Accuracy (Need 20 minute preheating to get enhanced accuracy.)	Recommend Input Range - $\pm 0.1\%$ Recommended Scale @ 25°C ambient - $\pm 0.3\%$ Recommended Scale @ -40°C~70°C C/D Type Recommend Input Range - $\pm 0.3\%$ Recommended Scale @ -40°C~70°C External Cold Junction(PT100) - $\pm 2^\circ\text{C}$ Recommended Scale @ -40°C~70°C																																																
Connection Method	2-Wire																																																
Conversion Time	Average Conversion Time < 200ms																																																
Data Format	16 Bits Integer (2' complement)																																																
Calibration	Not Required																																																
Cold Junction Temperature	Internal - TMP275AIDGKR : -40°C~125°C External - PT100 : -45°C~95°C																																																
Diagnostic	Sensor open or range over, then conversion data = 0x8000(-32768) *Connected External CJ : CJ LED On. Not Connected External CJ : CJ LED Off.																																																
General Specification																																																	
Power Dissipation	Max. 130mA @ 5Vdc																																																

Isolation	I/O to Logic : Photocoupler Isolation Field power : Not Connected
Field Power	Not used, Field Power passes through to the next module
Wiring	I/O Cable Max. 2.0mm ² (AWG 14)
Weight	60g
Module Size	12mm x 99mm x 70mm
Environment Condition	Refer to 'Environment Specification'

* To increase precision of measurement, the connection between GT-3804 and compensation reference sensor is recommended using by terminal block.

3.3.6 Mapping Data into the Image Table

- **Input Module Data**

	Analog Input Ch0
	Analog Input Ch1
	Analog Input Ch2
	Analog Input Ch3

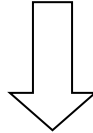

- **Input Image Value**

Bit No	Bit7	Bit6	Bit5	Bit4	Bit3	Bit2	Bit1	Bit0
Byte 0	Analog Input Ch0 Low byte							
Byte 1	Analog Input Ch0 High byte							
Byte 2	Analog Input Ch1 Low byte							
Byte 3	Analog Input Ch1 High byte							
Byte 4	Analog Input Ch2 Low byte							
Byte 5	Analog Input Ch2 High byte							
Byte 6	Analog Input Ch3 Low byte							
Byte 7	Analog Input Ch3 High byte							

- If the input of channel is open or over-ranged, its conversion data will be 0x8000(-32678)

3.3.7. Configuration Parameter – 8 Bytes

Byte	Decimal Bit	Description	Default Value
0	00-07	The selection Sensor Type =00h: Type K, 0.1°C/count =01h: Type J, 0.1°C/count =02h: Type T, 0.1°C/count =03h: Type B, 0.1°C/count =04h: Type R, 0.1°C/count =05h: Type S, 0.1°C/count =06h: Type E, 0.1°C/count =07h: Type N, 0.1°C/count =08h: Type L, 0.1°C/count =09h: Type U, 0.1°C/count =0Ah: Type C, 0.1°C/count =0Bh: Type D, 0.1°C/count =80h: 10uV Input, -81.0~81.0mV, 10uV / 1count =81h: 1uV Input, -32.7~32.7mV, 1uV / 1count =82h: 2uV Input, -65.5~65.5mV, 2uV / 1count =Others: Reserved	00 : Type K
1	00	Temperature Type 0: Celsius(°C), 1: Fahrenheit(°F)	00 : Celsius(°C) Cold Junction Compensation 0.1°C Normal Filter
	01*	0: Cold Junction Compensation 1: Disable Cold Junction Compensation	
	02	Data Resolution 0: 0.1°C, °F/bit, 1: 1°C, °F/bit	
	03	Reserved	
	04	Filter Type 0: Normal Filter, 1: Enhanced Filter	
	05-07	Reserved	
2	00-07	Internal Cold Junction[1] Offset Data Low Byte	0000
3	00-07	Internal Cold Junction[1] Offset Data High Byte	
4	00-07	Internal Cold Junction[2] Offset Data Low Byte	0000
5	00-07	Internal Cold Junction[2] Offset Data High Byte	
6	00-07	External Cold Junction Offset Data Low Byte	0000
7	00-07	External Cold Junction Offset Data High Byte	

- Unit of Cold Junction Temperature is 0.1°C/°F. Value 254 means 25.4°C or 25.4°F
- *0: Compensation Cold Junction Temperature = Cold Junction Temperature – Cold Junction Temperature Offset
- *1: Compensation Cold Junction Temperature = Cold Junction Temperature Offset

3.3.8. Data Value

Thermocouple Input Range		
Type	Maximum Input Range	Recommended Input Range
Type K	-270 ~ 1372 °C	-200 ~ 1200 °C
Type J	-210 ~ 1200 °C	-40 ~ 1100 °C
Type T	-270 ~ 400 °C	-200 ~ 350 °C
Type B	30 ~ 1820 °C	600 ~ 1700 °C
Type R	-50 ~ 1768 °C	0 ~ 1600 °C
Type S	-50 ~ 1768 °C	0 ~ 1600 °C
Type E	-270 ~ 1000 °C	-200 ~ 800 °C
Type N	-270 ~ 1300 °C	-200 ~ 1250 °C
Type L	-200 ~ 900 °C	-100 ~ 850 °C
Type U	-200 ~ 600 °C	-100 ~ 550 °C
Type C	0 ~ 2310 °C	100 ~ 2100 °C
Type D	0 ~ 2490 °C	100 ~ 2200 °C
10uV	-81.0 ~ 81.0mV, 10uV/ 1 Count	
1uV	-32.7 ~ 32.7mV, 1uV/ 1 Count	
2uV	-65.5 ~ 65.5mV, 2uV/ 1 Count	

- °F = 1.8°C+32

3.4. GT-3808

3.4.1. Wiring Diagram

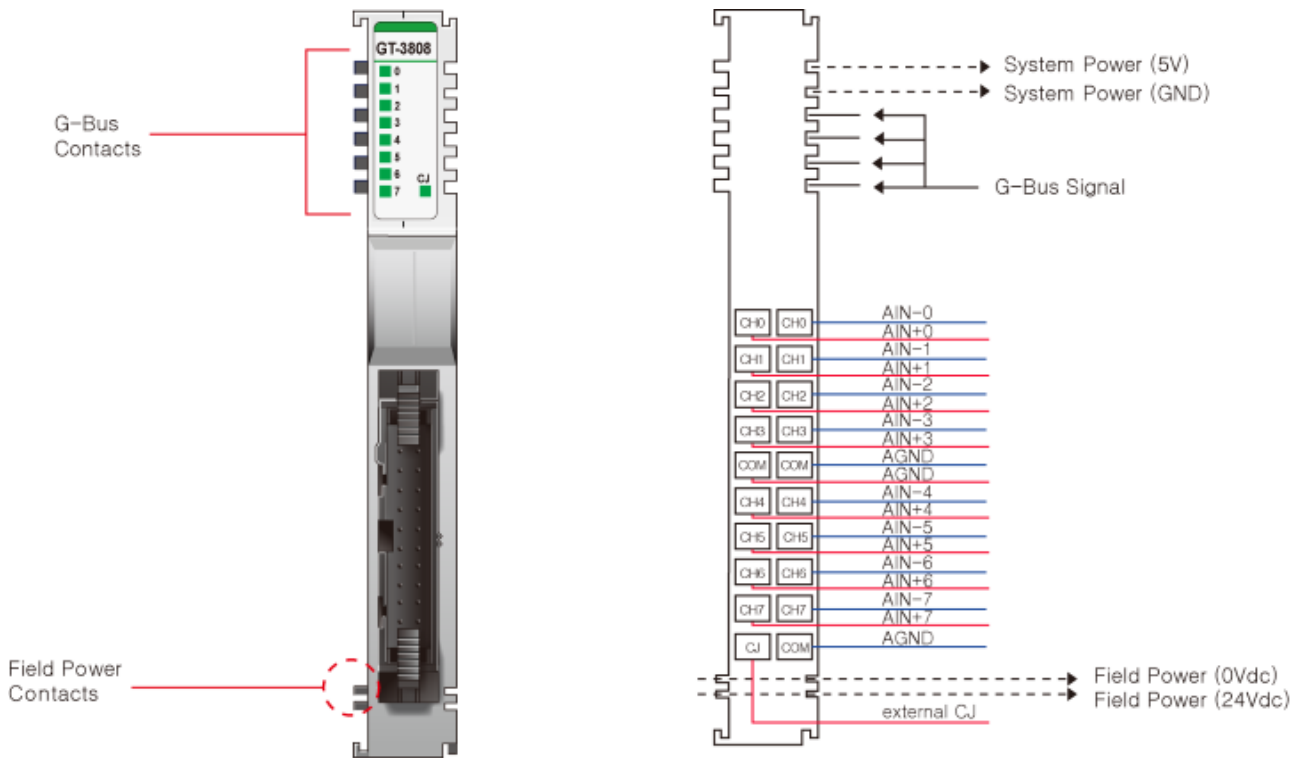
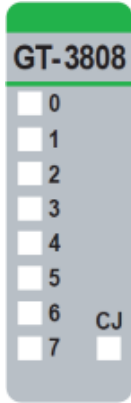

Figure 1. Customer Wiring to Mounting Base

Pin No.	Signal Description	Signal Description	Pin No.
0	TC Channel 0+	TC Channel 0-	1
2	TC Channel 1+	TC Channel 1-	3
4	TC Channel 2+	TC Channel 2-	5
6	TC Channel 3+	TC Channel 3-	7
8	AGND	AGND	9
10	TC Channel 4+	TC Channel 4-	11
12	TC Channel 5+	TC Channel 5-	13
14	TC Channel 6+	TC Channel 6-	15
16	TC Channel 7+	TC Channel 7-	17
18	Cold Junction Sensor	AGND	19

3.4.2 LED Indicator



LED No.	LED Function / Description	LED Color
0	Input Channel 0	Green
1	Input Channel 1	Green
2	Input Channel 2	Green
3	Input Channel 3	Green
4	Input Channel 4	Green
5	Input Channel 5	Green
6	Input Channel 6	Green
7	Input Channel 7	Green
CJ	Input Channel CJ	Green

3.4.3. Channel Status LED

Status	LED	To indicate
No Signal	Channel Off, CJ Off	Input Sensor Open or Input Range Over
Normal Operation		Normal Operation
On Signal	Channel On, CJ Off	Sensor Connected and Input Range Valid
Normal Operation		Normal Operation
On Signal	Channel On, CJ On	Sensor Connected and Input Range Valid
Normal Operation		Normal Operation
Connected External CJC		External CJ Enable

3.4.4. Environment Specification

Environmental Specification	
Operation Temperature	-40°C ~ 70°C
UL Temperature	-20°C ~ 60°C
Storage Temperature	-40°C ~ 85°C
Relative Humidity	5% ~ 90% Non-condensing
Mounting	DIN Rail
General Specification	
Shock Operating	IEC 60068-2-27
Vibration Resistance	Based on IEC 60068-2-6 Sine Vibration - 5 ~ 25Hz : ±1.6mm - 25 ~ 300Hz : 4g - Sweep Rate : 1 Oct/min, 20 Sweeps Random Vibration - 10 ~ 40 Hz : 0.0125 g ² /Hz - 40 ~ 100 Hz : 0.0125 → 0.002 g ² /Hz - 100 ~ 500 Hz : 0.002 g ² /Hz - 500 ~ 2000 Hz : 0.002 → 1.3 x 10 ⁻⁴ g ² /Hz - Test time : 1hrs for each test
EMC Resistance Burst/ESD	EN 61000-6-2 : 2005 EN61000-6-4/All : 2011
Protection Class	Variable/IP20
Installation Position	Vertical and horizontal installation is available
Product Certifications	CE, UL

3.4.5. Specification

Items	Specification
Input Specification	
Inputs Per Module	8 Channels
Indicators	8 Green Input Status LEDs , 1 Green Input CJ Status LED
Sensor Types	Thermal Couple Input Range

Type	Maximum Input Range	Recommended Input Range
K	-270 ~ 1372°C	-200 ~ 1200°C
J	-210 ~ 1200°C	-40 ~ 1100°C
T	-270 ~ 400°C	-200 ~ 350°C
B	30 ~ 1820°C	600 ~ 1700°C
R	-50~1768°C	0 ~ 1600°C
S	-50 ~ 1768°C	0 ~ 1600°C
E	-270 ~ 1000°C	-200 ~ 800°C
N	-270 ~ 1300°C	-200 ~ 1250°C
L	-200 ~ 900°C	-100 ~ 850°C
U	-200 ~ 600°C	-100 ~ 550°C
C	0 ~ 2310°C	100 ~ 2100°C
D	0 ~ 2490°C	100 ~ 2200°C
10uV Input	-81.0 ~ 81.0mV, 10uV/1 Count	
1uV Input	-32.7 ~ 32.7mV, 1uV/1 Count	
2uV Input	-65.5 ~ 65.5mV, 2uV/1 Count	
Module Accuracy (Need 20 minute preheating to get enhanced accuracy.)	Recommend Input Range - $\pm 0.1\%$ Recommended Scale @ 25°C ambient - $\pm 0.3\%$ Recommended Scale @ -40°C~70°C T,B,R,S,C,D Type Recommend Input Range - $\pm 0.3\%$ Recommended Scale @ -40°C~70°C External Cold Junction(PT100) - $\pm 2^\circ\text{C}$ Recommended Scale @ -40°C~70°C	
Connection Method	2-Wire	
Conversion Time	Average Conversion Time < 330ms	
Data Format	16 Bits Integer (2' complement)	
Calibration	Not Required	
Cold Junction Temperature	Internal - TMP275AIDGKR : -40°C~125°C External - PT100 : -45°C~95°C	
Diagnostic	Sensor open or range over, then conversion data = 0x8000(-32768) *Connected External CJ : CJ LED On. Not Connected External CJ : CJ LED Off.	
General Specification		
Power Dissipation	Max. 150mA @ 5Vdc	
Isolation	I/O to Logic : Photocoupler Isolation Field Power : Not Connected	
Field Power	Not used, Field Power passes through to the next module	
Wiring	I/O Cable Max. 2.0mm ² (AWG 14)	
Weight	60g	
Module Size	12mm x 99mm x 70mm	
Environment Condition	Refer to 'Environment Specification'	

3.4.6. Mapping Data into the Image Table

- **Input Module Data**

	Analog Input Ch0
	Analog Input Ch1
	Analog Input Ch2
	Analog Input Ch3
	Analog Input Ch4
	Analog Input Ch5
	Analog Input Ch6
	Analog Input Ch7

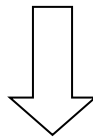

- **Input Image Value**

Bit No	Bit7	Bit6	Bit5	Bit4	Bit3	Bit2	Bit1	Bit0
Byte 0				Analog Input Ch0 Low byte				
Byte 1				Analog Input Ch0 High byte				
Byte 2				Analog Input Ch1 Low byte				
Byte 3				Analog Input Ch1 High byte				
Byte 4				Analog Input Ch2 Low byte				
Byte 5				Analog Input Ch2 High byte				
Byte 6				Analog Input Ch3 Low byte				
Byte 7				Analog Input Ch3 High byte				
Byte 8				Analog Input Ch4 Low byte				
Byte 9				Analog Input Ch4 High byte				
Byte 10				Analog Input Ch5 Low byte				
Byte 11				Analog Input Ch5 High byte				
Byte 12				Analog Input Ch6 Low byte				
Byte 13				Analog Input Ch6 High byte				
Byte 14				Analog Input Ch7 Low byte				
Byte 15				Analog Input Ch7 High byte				

- If the input of channel is open or over-ranged, its conversion data will be 0x8000(-32678)

3.4.7. Configuration Parameter – 8 Bytes

Byte	Decimal Bit	Description	Default Value
0	00-07	The selection Sensor Type =00h: Type K, 0.1°C/count =01h: Type J, 0.1°C/count =02h: Type T, 0.1°C/count =03h: Type B, 0.1°C/count =04h: Type R, 0.1°C/count =05h: Type S, 0.1°C/count =06h: Type E, 0.1°C/count =07h: Type N, 0.1°C/count =08h: Type L, 0.1°C/count =09h: Type U, 0.1°C/count =0Ah: Type C, 0.1°C/count =0Bh: Type D, 0.1°C/count =80h: 10uV Input, -81.0~81.0mV, 10uV / 1count =81h: 1uV Input, -32.7~32.7mV, 1uV / 1count =82h: 2uV Input, -65.5~65.5mV, 2uV / 1count =Others: Reserved	00 : Type K
1	00	Temperature Type 0: Celsius(°C), 1: Fahrenheit(°F)	00 : Celsius(°C) Cold Junction Compensation 0.1°C Normal Filter
	01*	0: Cold Junction Compensation 1: Disable Cold Junction Compensation	
	02	Data Resolution 0: 0.1°C, °F/bit, 1: 1°C, °F/bit	
	03	Reserved	
	04	Filter Type 0: Normal Filter, 1: Enhanced Filter	
	05-07	Reserved	
2	00-07	Internal Cold Junction[1] Offset Data Low Byte	0000
3	00-07	Internal Cold Junction[1] Offset Data High Byte	
4	00-07	Internal Cold Junction[2] Offset Data Low Byte	0000
5	00-07	Internal Cold Junction[2] Offset Data High Byte	
6	00-07	External Cold Junction Offset Data Low Byte	0000
7	00-07	External Cold Junction Offset Data High Byte	

- Unit of Cold Junction Temperature is 0.1°C/°F. Value 254 means 25.4°C or 25.4°F

- *0: Compensation Cold Junction Temperature = Cold Junction Temperature – Cold Junction Temperature Offset

- *1: Compensation Cold Junction Temperature = Cold Junction Temperature Offset

3.4.8. Data Value

Thermocouple Input Range		
Type	Maximum Input Range	Recommended Input Range
Type K	-270 ~ 1372 °C	-200 ~ 1200 °C
Type J	-210 ~ 1200 °C	-40 ~ 1100 °C
Type T	-270 ~ 400 °C	-200 ~ 350 °C
Type B	30 ~ 1820 °C	600 ~ 1700 °C
Type R	-50 ~ 1768 °C	0 ~ 1600 °C
Type S	-50 ~ 1768 °C	0 ~ 1600 °C
Type E	-270 ~ 1000 °C	-200 ~ 800 °C
Type N	-270 ~ 1300 °C	-200 ~ 1250 °C
Type L	-200 ~ 900 °C	-100 ~ 850 °C
Type U	-200 ~ 600 °C	-100 ~ 550 °C
Type C	0 ~ 2310 °C	100 ~ 2100 °C
Type D	0 ~ 2490 °C	100 ~ 2200 °C
10uV	-81.0 ~ 81.0mV, 10uV/ 1 Count	
1uV	-32.7 ~ 32.7mV, 1uV/ 1 Count	
2uV	-65.5 ~ 65.5mV, 2uV/ 1 Count	

$$^{\circ}\text{F} = 1.8^{\circ}\text{C} + 32$$

4. Dimension

4.1. GT-3xx4(RTB), GT-3xx8(RTB)

(mm)

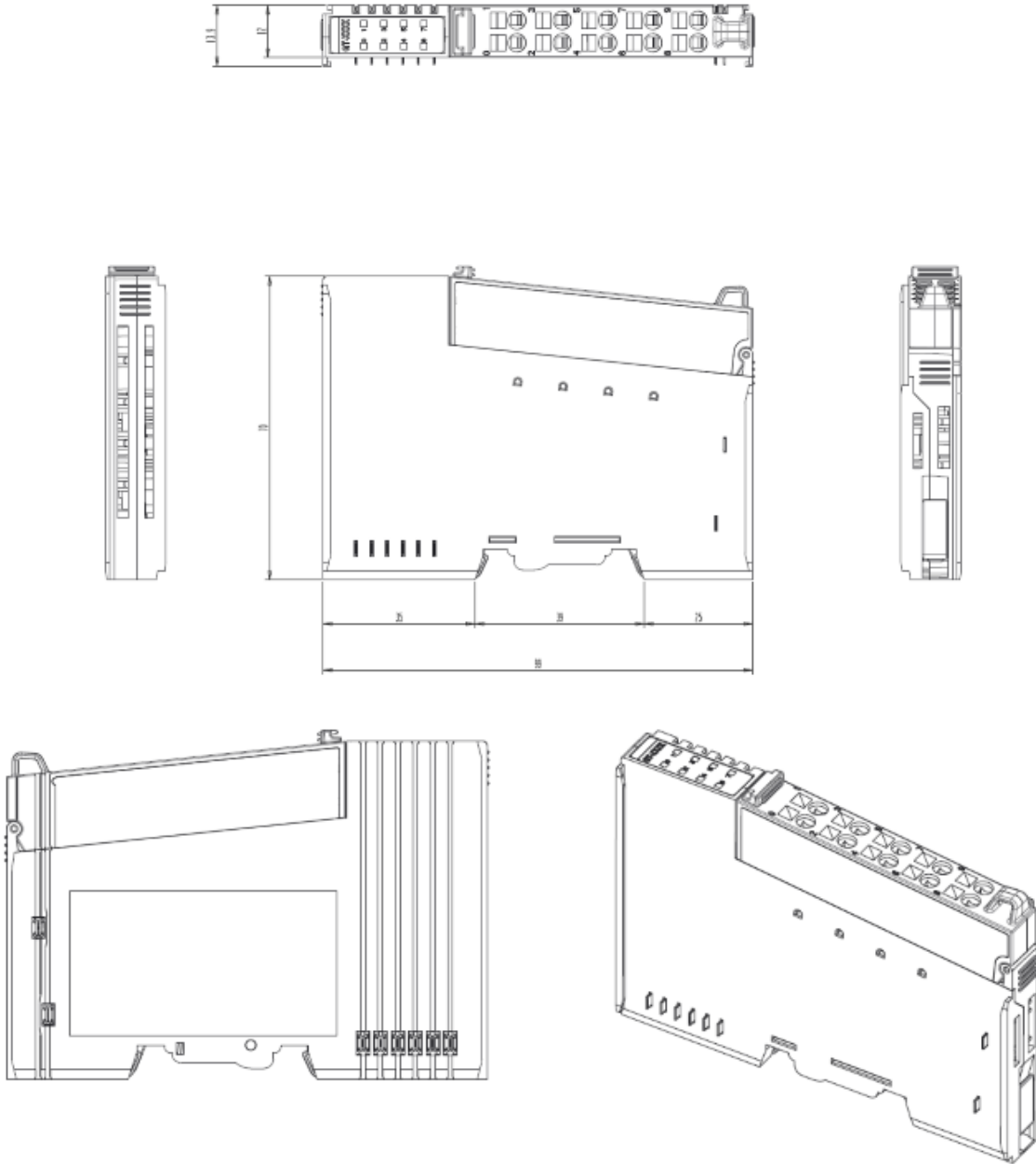

4.2. GT-3xxF(Connector)

(mm)

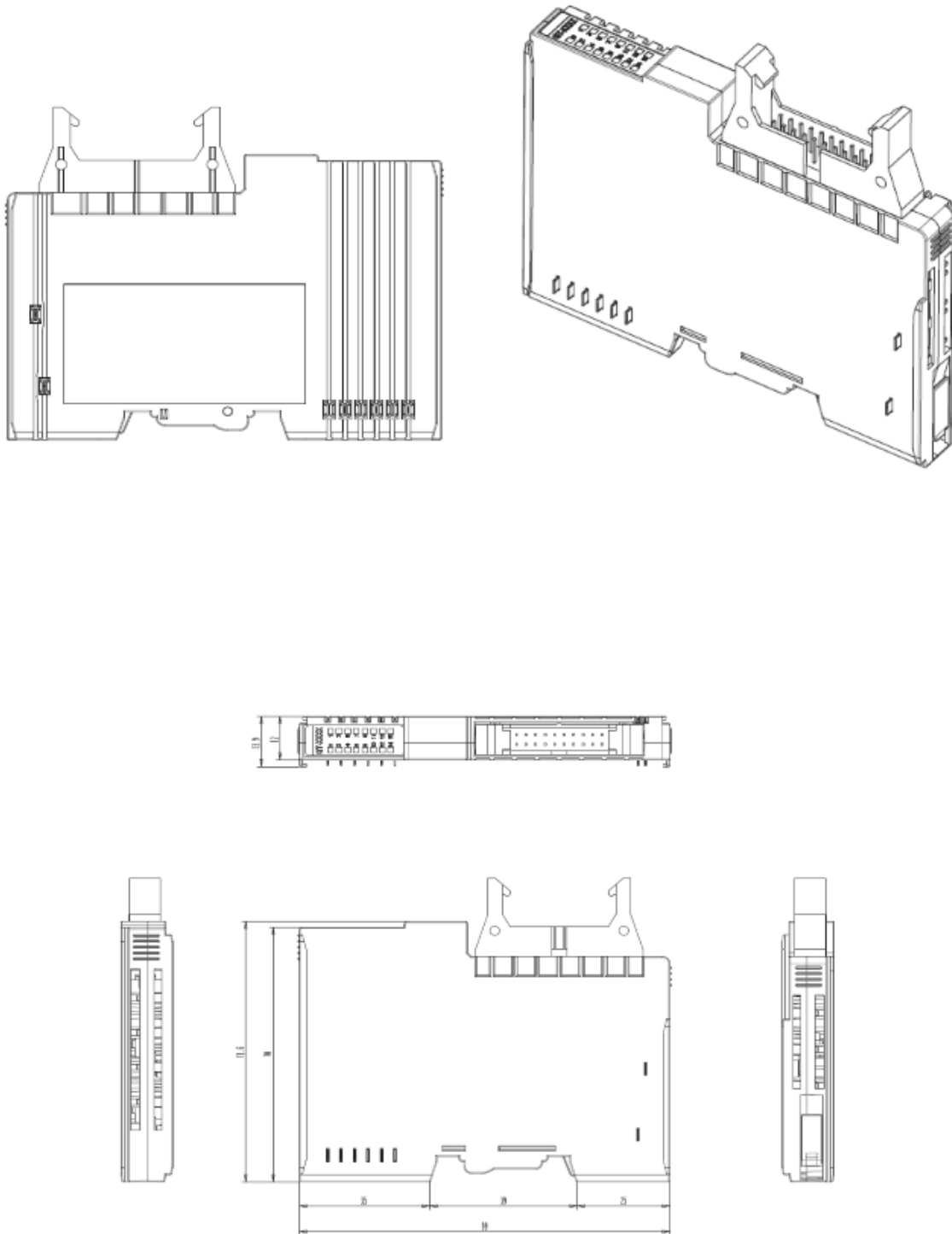

5. Mounting

Caution!

- **Hot surface!**

The surface of the housing can become hot during operation. If the device was operated at high ambient temperatures, allow it to be cool before touching it.

Notice!

- **Perform work on devices only if they are de-energized!**

Working on energized devices can damage them. Therefore, turn off the power supply before working on the devices.

5.1. I/O Inserting and Removing Devices

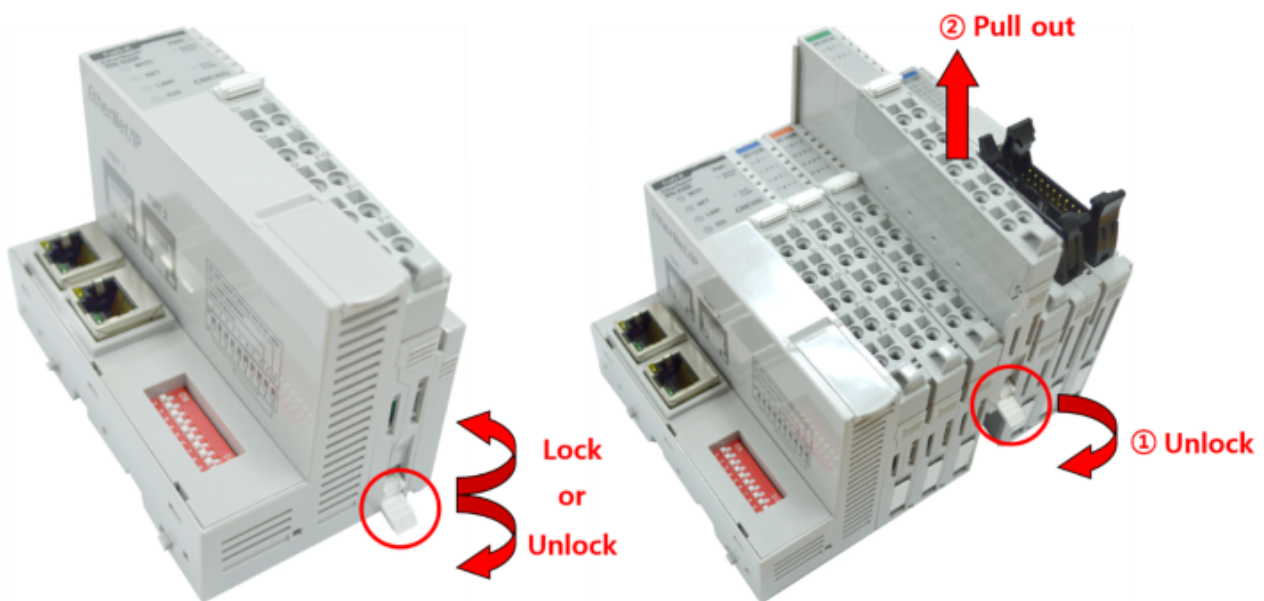

- As above figure in order to safeguard the G-Series module from jamming, it should be fixed onto the DIN rail with locking level. To do so, fold on the upper of the locking lever.
- To pull out the G-Series module, unfold the locking lever as below figure.

5.2. RTB (Removable Terminal Block)

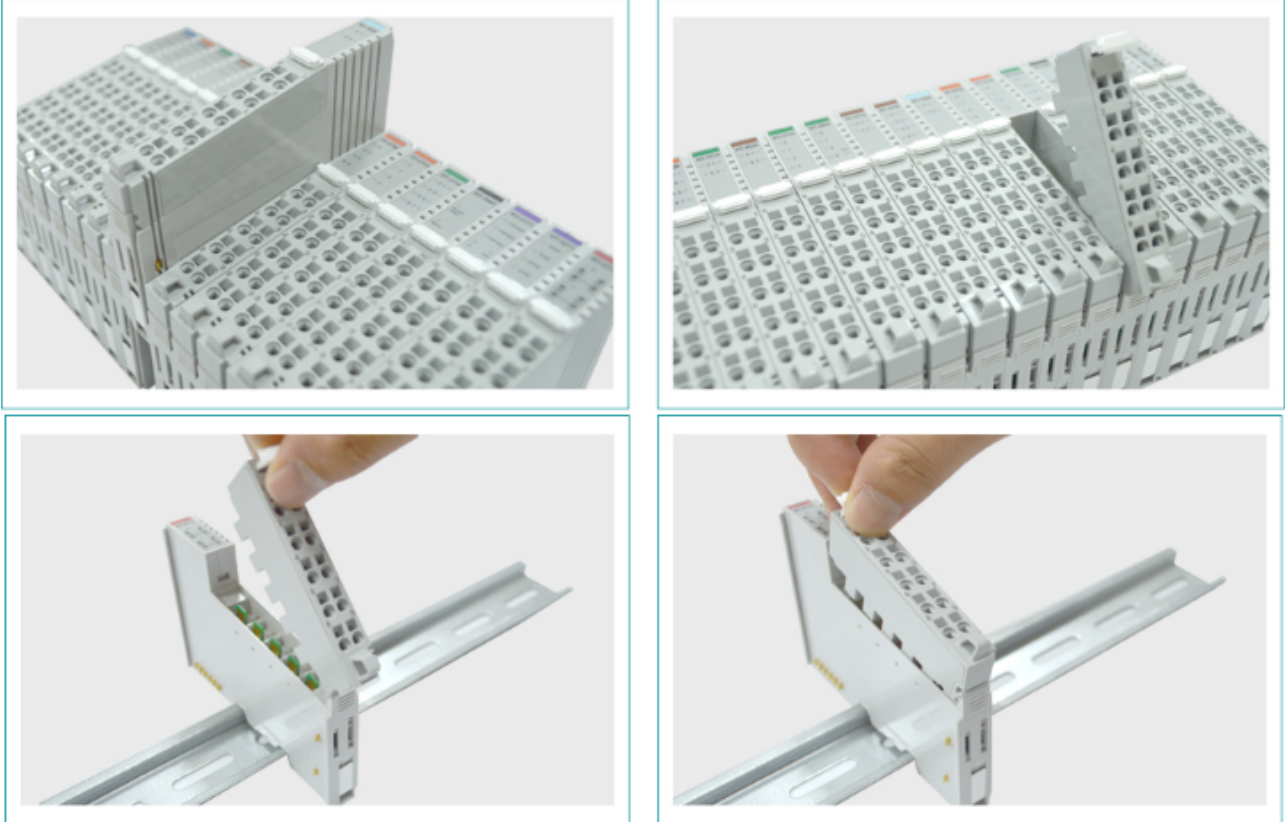

- Whole terminal block can be combined and removed for the convenience.
- There is a locking switch on the RTB for the easy combination and easy removal.
- Easy combination and easy removal for IO modules on the din rail through One Touch Locking Switch.

6. G-Bus Pin Description

Communication between the GN series and the expansion module as well as system / field power supply of the bus modules is carried out via the internal bus. It is comprised of 6 data pin and 2 field power pin.

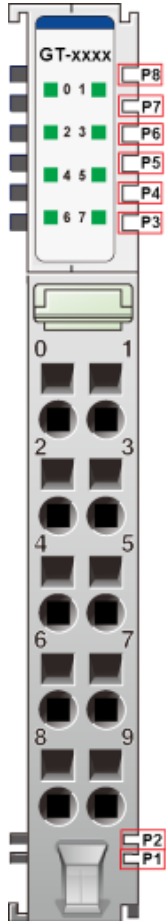

*Please refer to the table below regarding the pin description from P1 to P8.

No.	Description
P1	Field Power (VCC)
P2	Field Power (GND)
P3	GBUS CLK
P4	GBUS MISO
P5	GBUS MOSI
P6	GBUS Token
P7	System Power (GND)
P8	System Power (VCC)

DANGER



Do not touch data and field power pins in order to avoid soiling and damage by ESD noise.